

NOTE:  
 LOCATION OF WATER METER IN RELATION TO OTHER PERMANENT FIXTURES (FURNACE, WATER HEATER, ETC.) MUST ALLOW MINIMUM OF 0.8m (30") CLEARANCE NECESSARY FOR ANY FUTURE METER REPAIR OR REMOVAL.

WATER METER MUST NOT BE ENCLOSED WITHIN WALLS AND MUST REMAIN READILY ACCESSIBLE TO TOWN PERSONNEL.

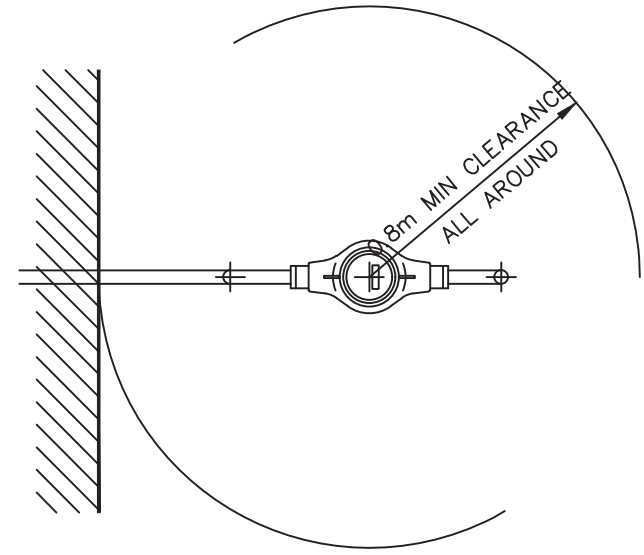

PLAN



No.	Revision Date	No.	Revision Date
		1	MARCH 18, 2020